

PROFIL ZA IZRADU FRONTA RAM 1007

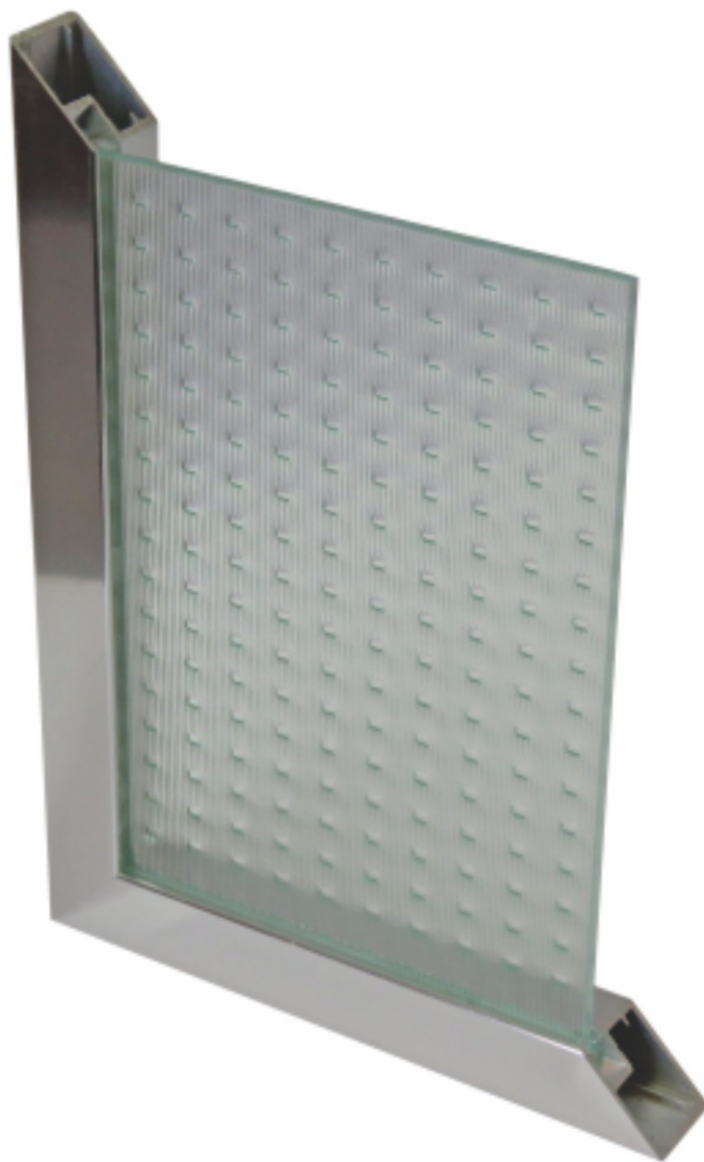

euro*profil*

Aluminijumski profil RAM 1007.

Profil RAM 1007 koristi se za izradu aluminijumskih ramova (front korpusa), od staklene ispune debljine 4mm.

Prilikom izrade Al rama, dimenzija stakla umanjuje se za 30mm od ukupne dimenzije aluminijumskog rama.

Za kačenje Al rama za korpus, koriste se specifične šarke koje se ukopavaju i mogu biti sa ili bez integrisanih usporivača. PVC profil koji se postavlja unutar samog rama odvaja staklo od konstrukcije, tj. sprečava direktan dodir stakla i aluminijuma. Završna obrada profila je hemijska eloksaža i dostupna je u nekoliko boja: srebro mat, srebro sjaj, brušena bronza, crna mat i chocco.

Šarke se ukopavaju u RAM 1007 Al profil.

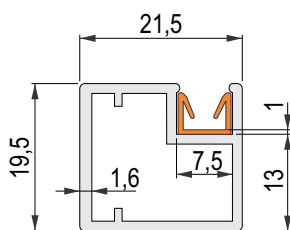
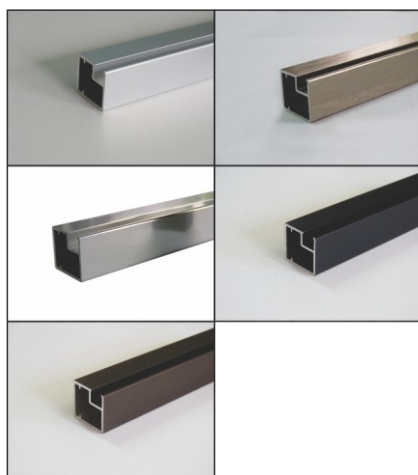

RAM 1007 Al profil

			šifra			šifra
6m	mat srebro		5089	6m	crna mat	6954
5,5m	bronza brušena		5275	6m	chocco	7002
5,5m	sjaj srebro		5276			

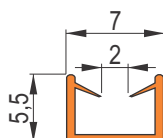

PVC ispuna - dva pera

			šifra
3m	bela		4965

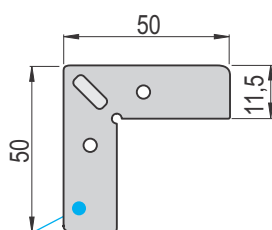

Metalni ugao - RAM 1007

			šifra
kom	srebro		5090

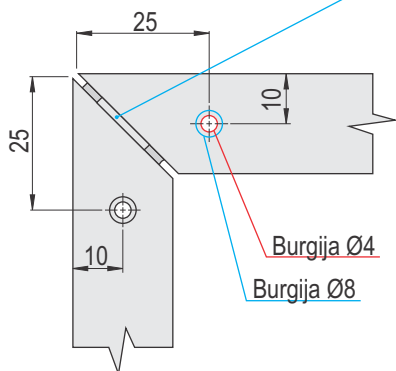

* Potrebno je upustiti (frezenkovati) rupu za šraf sa burgijom Ø8, da bi glava šrafa bila u ravni sa profilom.

Šarka ravna

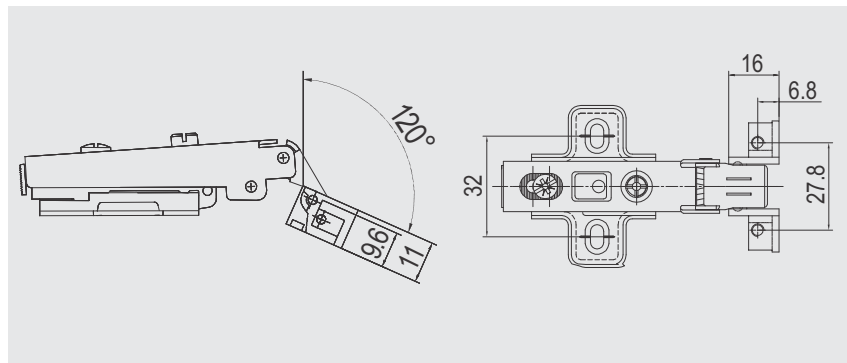

Šarka polu-koleno

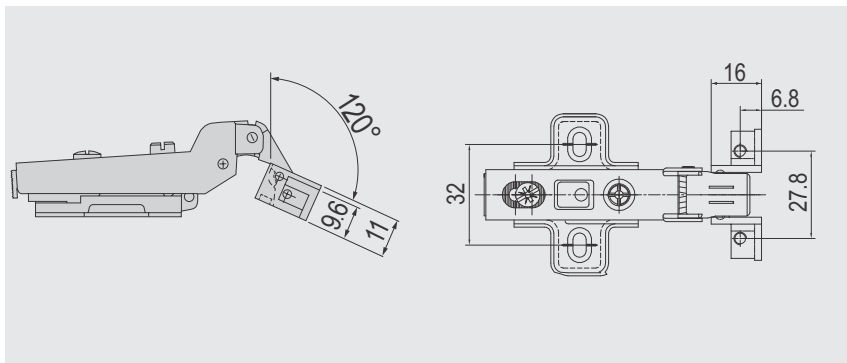

Šarka koleno

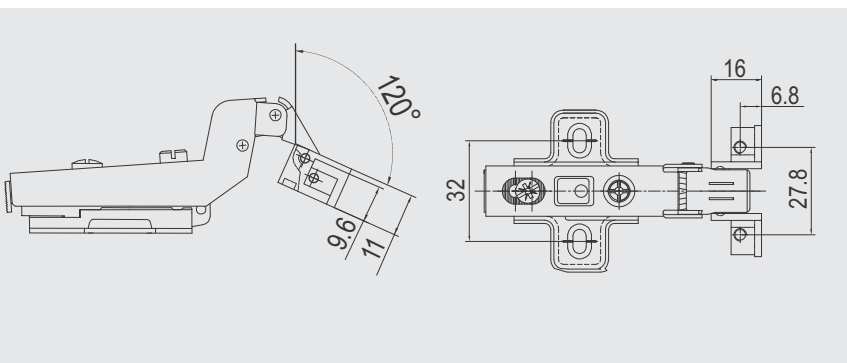

kom.	nikl	šifra	
kom.	nikl	5095	ravna
kom.	nikl	5984	ravna-usporivač
kom.	nikl	5096	polukoleno
kom.	nikl	5097	koleno

RAM 1007 - Ukopavanje otvora za montažu šarki !!!

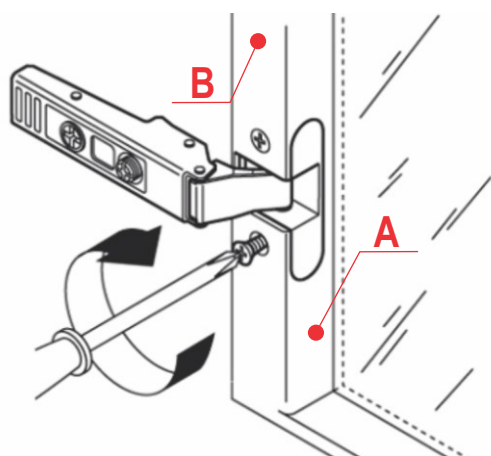

1 Otvor za šarku (glodalo)

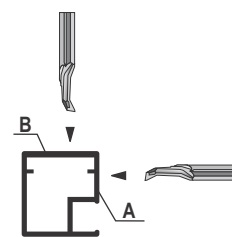
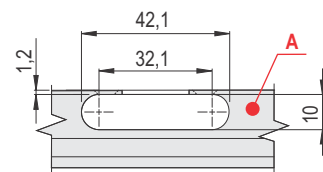

2 Rupe za vijke (burgija)

