

RAM 1009 profili za izradu staklenih frontova

RAM 1009 profil za front AL SM



art.	j.m.	boja
7125	m	srebro mat
Prodajne dužine (m): 3,0 i 6,0		

RAM 1009 profil za front AL BBM



art.	j.m.	boja
7127	m	bruš.bronza
Prodajne dužine (m): 3,0 i 6,0		

RAM 1009 profil za front AL CRNA



art.	j.m.	boja
7126	m	crna mat
Prodajne dužine (m): 3,0 i 6,0		

Šarke i umeci za 1009 ramove



art.	j.m.	boja
9943	set	tamni niki

Ankor DS 30 ugaonici za sklopanje rama



art.	j.m.	boja
8884	kom	metal

RAM PVC ispuna za staklo LIANA

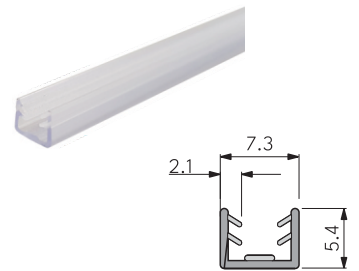

art.	j.m.	boja
7165	m	transp.
Prodajne dužine (m): 3,0		

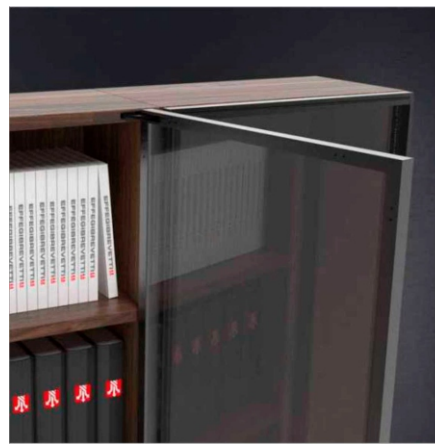

Tehnički detalji profila za izradu fronta

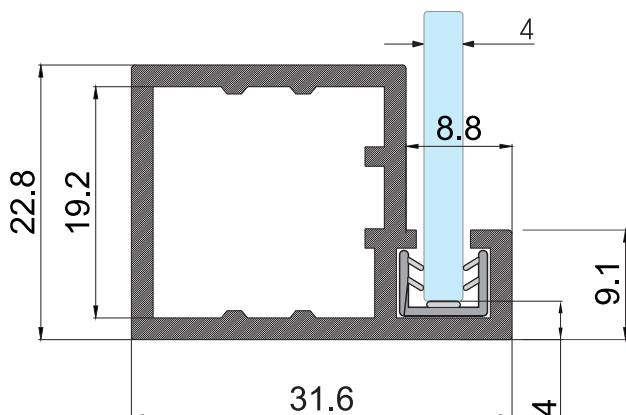

Visina staklene ispune = Visina fronta - 8mm
 Širina staklene ispune = Širina fronta - 8mm

RAM 1009 profili za izradu staklenih frontova

Pozicioniranje otvora za šarke u podu i plafonu korpusa i priprema Al profila

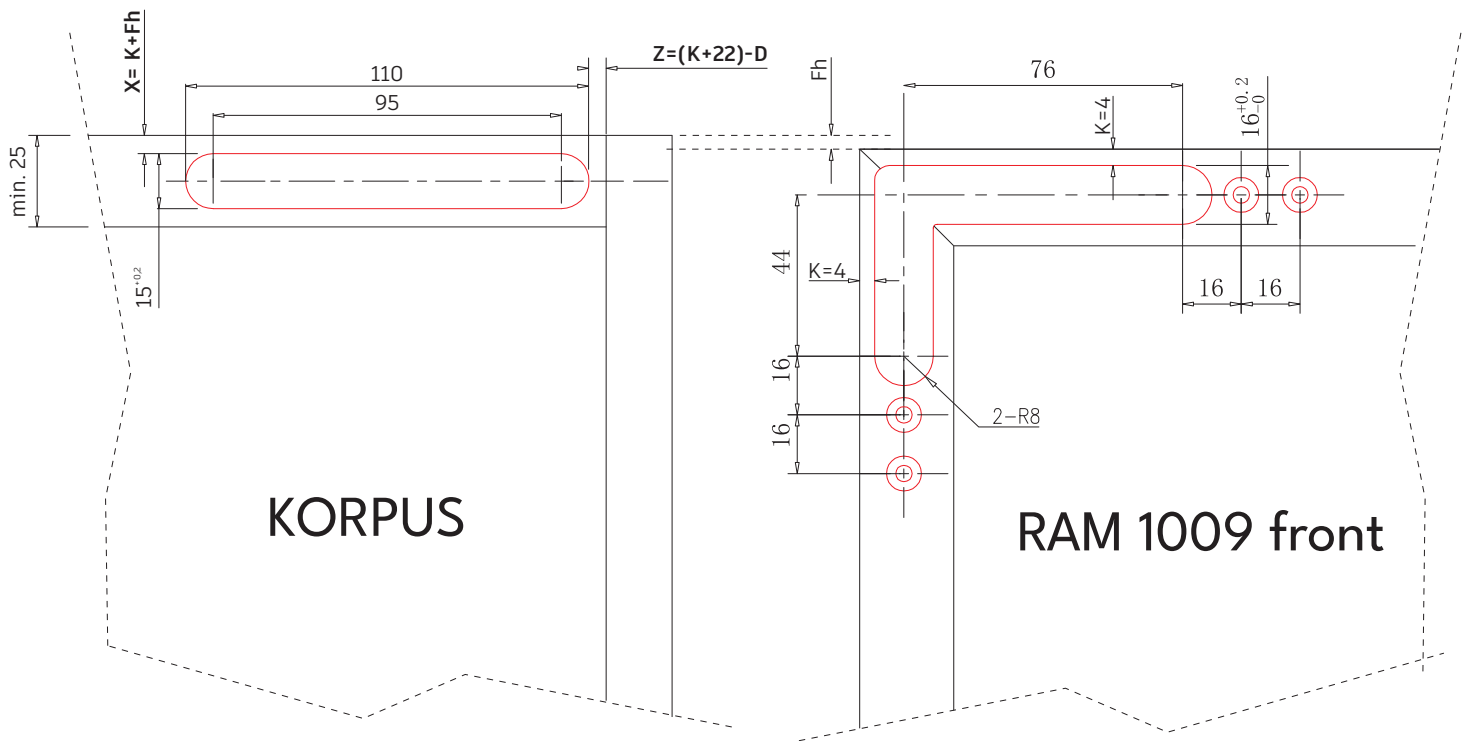

Priprema otovora u podu i plafonu korpusa kada se koristi umetak za šarku

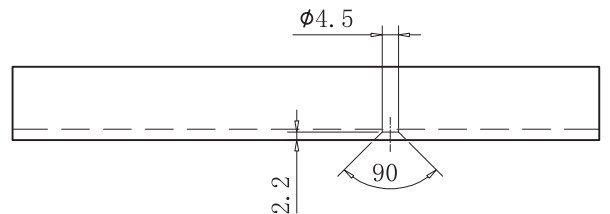
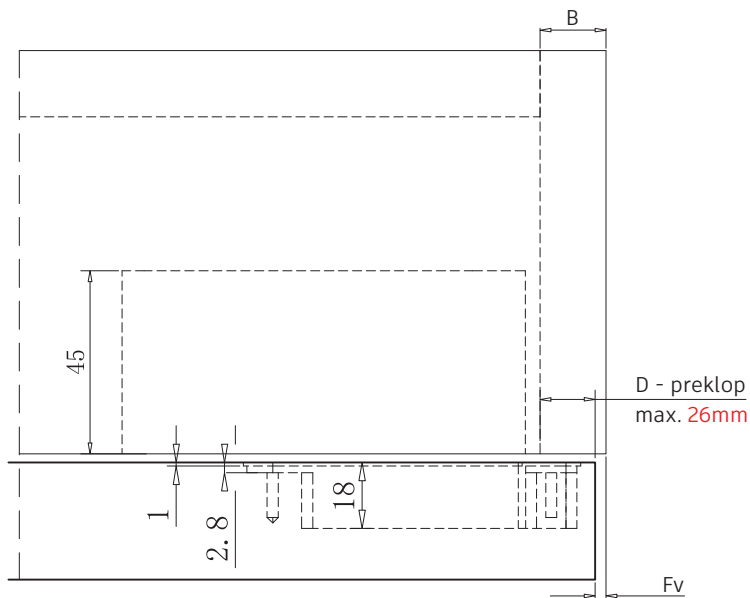

D - preklap fronta i korpusa
B - debljina bočne stranice
Fv - fuga vertikalna

K - udaljenost otvora za šarku od ivice Al fronta
Fh - fuga horizontalna

$$D = B - Fv$$

$$X = K + Fh$$

RAM 1009 profili za izradu staklenih frontova

Podešavanje lateralno: +3,5/-0,5

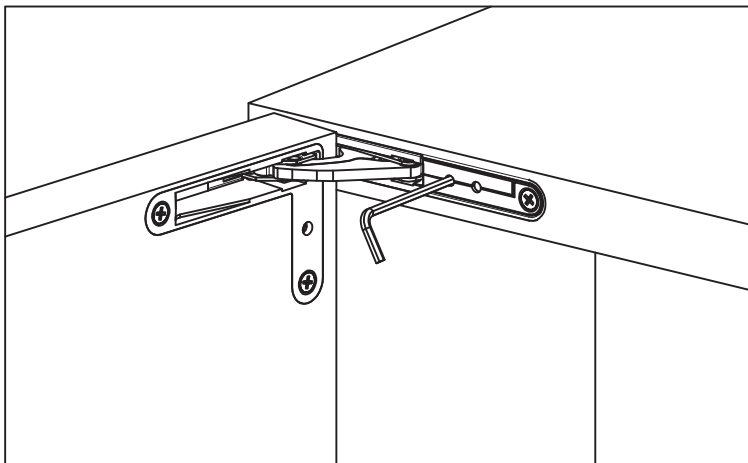
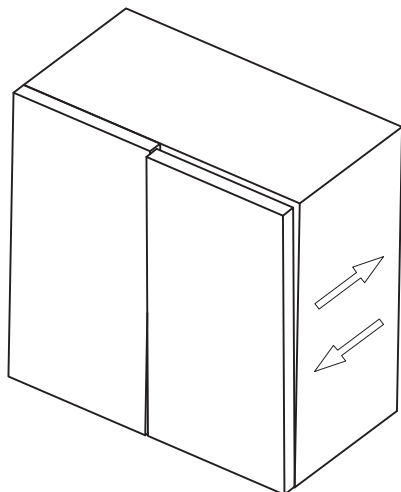

Podešavanje horizontalno: +2,0/-2,0

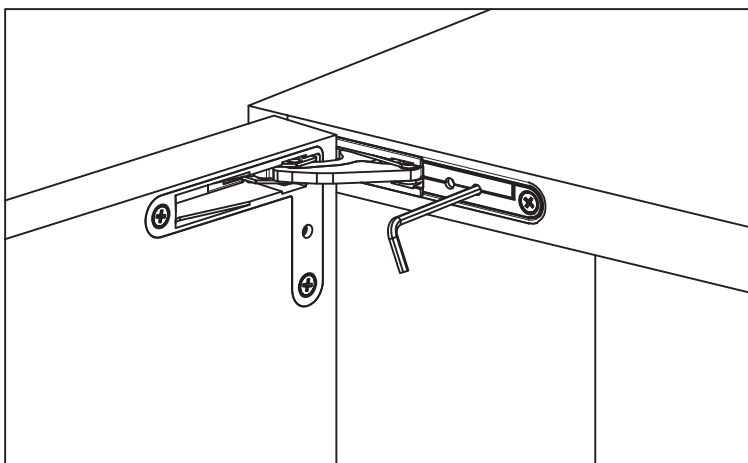
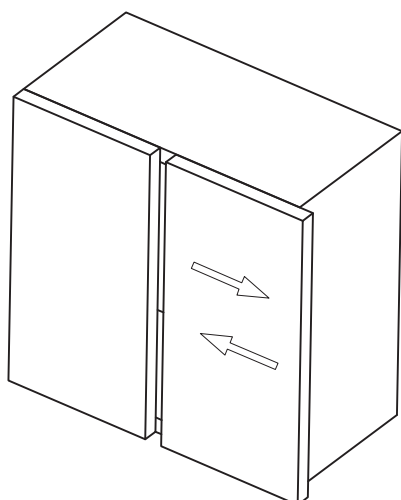

Podešavanje vertikalno: +1,0/-1,0

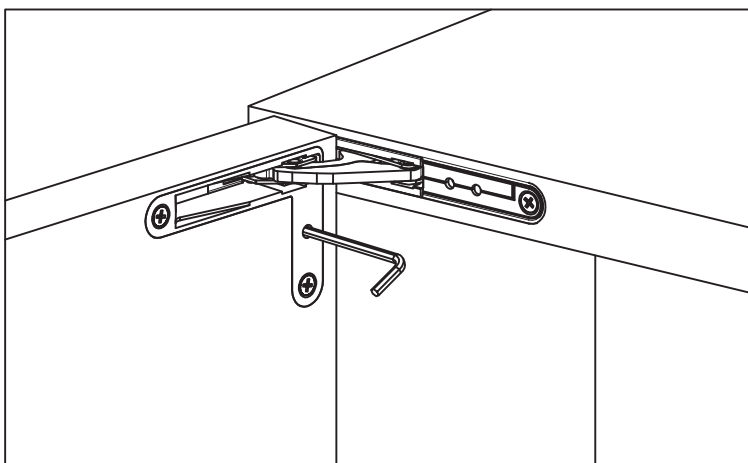
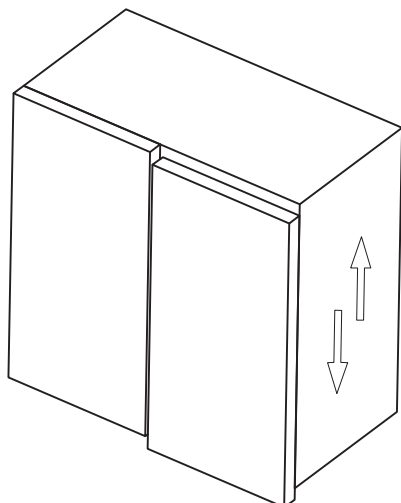

RAM 1009 profili za izradu staklenih frontova

Dekorativne folije za staklene frontove

NOVO!

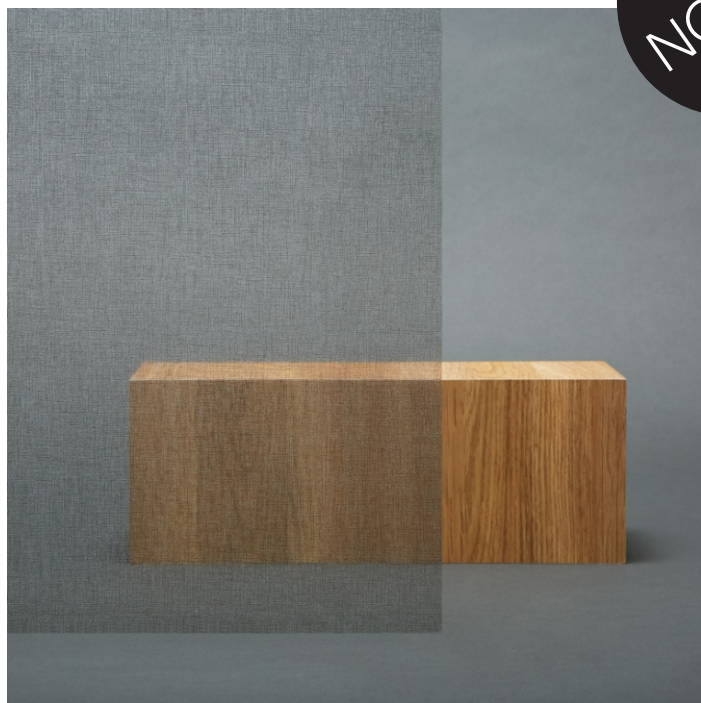

Buckram Pearl + Gray - art. 10188

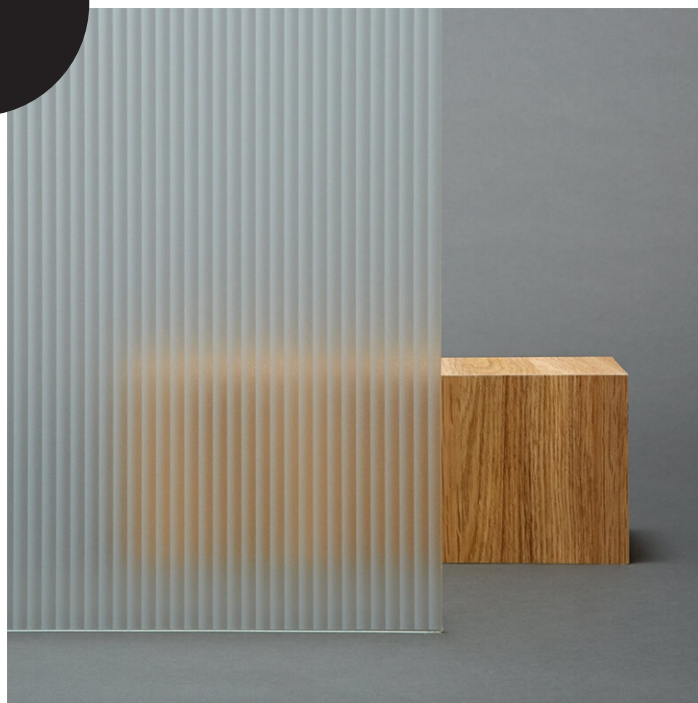

Seattle - art. 10187

Folije za staklene frontove se koriste u dekorativne svrhe prilikom izrade aluminijumskih ramova sa staklenim ispunama. Širina rolne je 127cm, a dužina rolne je 30m.

Dekoratívna folija se prodaje na dužni metar.

Za više detalja možete poslati upit na office@europrofil.rs

